



# Decorative Window Films



Engineered to Perform Better™



# ORAFOL Europe GmbH

## ORAFOL's Worldwide Locations





# Index

## Decorative Window Films

Page	List of contents
4	ORAFOL® Decorative Window Films
5	ORACAL® W001 White stripes of 4mm, Interior Design Window Film
6	ORACAL® W014 White squares of 20mm, Interior Design Window Film
7	ORACAL® UV05 Frosted stripes of 35mm, Interior Design Window Film
8	ORACAL® W002 White squares of 10mm, , Interior Design Window Film
9	ORACAL® W018 White Cocoon, Interior Design Window Film
10	ORACAL® W004 White stripes of 30mm, Interior Design Window Film
11	ORACAL® UV10 Frosted stripes of 5mm and 35mm, Interior Design Window Film
12	ORACAL® UV11 Frosted Squares of 44mm, Interior Design Window Film
13	ORACAL® WM20 White Matt Interior Design Window Film
14	ORACAL® 8300 Transparent Cal
15	ORAJET® 3352F Optical Clear Film
16	ORACAL® 8510 Etched Glass Cal
16	ORACAL® 8510 RA Etched Glass Cal – with RapidAir® Technology
17	ORACAL® 8530 Etched Glass Cal
18	ORACAL® 8710 Dusted Glass Cal
19	ORACAL® 8810 Frosted Glass Cast

### ORACAL Decorative Window Films;

ORACAL Decorative Window Films offer a tremendous cost advantage in comparison to etched glasses made in traditional methods. This product range includes window films that are developed for long term use and suitable for large size graphic projects.

ORACAL Decorative Window Films can be used on acrylic plastic sheets, windows of shops, offices, lobbies, restaurants and conference rooms. ORACAL Decorative Window Films are also used on windows, glass doors and separators by laboratories and hospitals for privacy issues.

These products provide glass design options of highest quality, without changing the glass structure or blocking sunlight.



Example of ORACAL® Decorative Window Films



## ORACAL Interior Design Window Films: Choose the pattern and apply!

Provided with a ready-to-apply decorative patterns, ORACAL Interior Design Window Films offer budget friendly decorative solutions. It is now easier to create different designs!

### White stripes of 4mm, Interior Design Window Film

# ORACAL<sup>®</sup> W001

**Product Features:**

- White Stripes of 4mm
- 38 micron
- Acrylic copolymer adhesive
- Roll size: 1525mm x 30m
- Wet application is recommended.

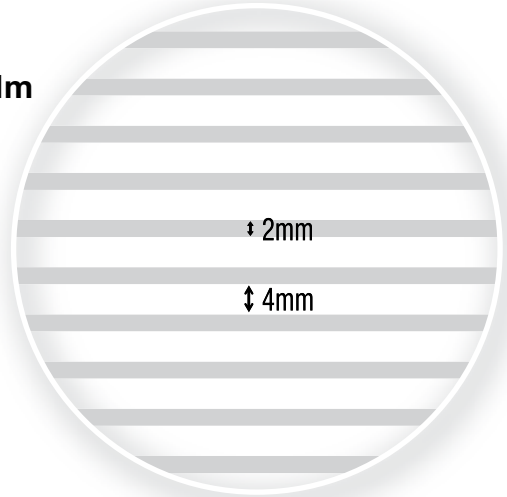

Example of ORACAL<sup>®</sup> Decorative Window Films

White Squares of 20mm, Interior Design Window Film

ORACAL® W014

**Product Features:**

- White Squares of 20mm
- 38 micron
- Acrylic copolymer adhesive
- Roll size: 1525mm x 30m
- Wet application is recommended.

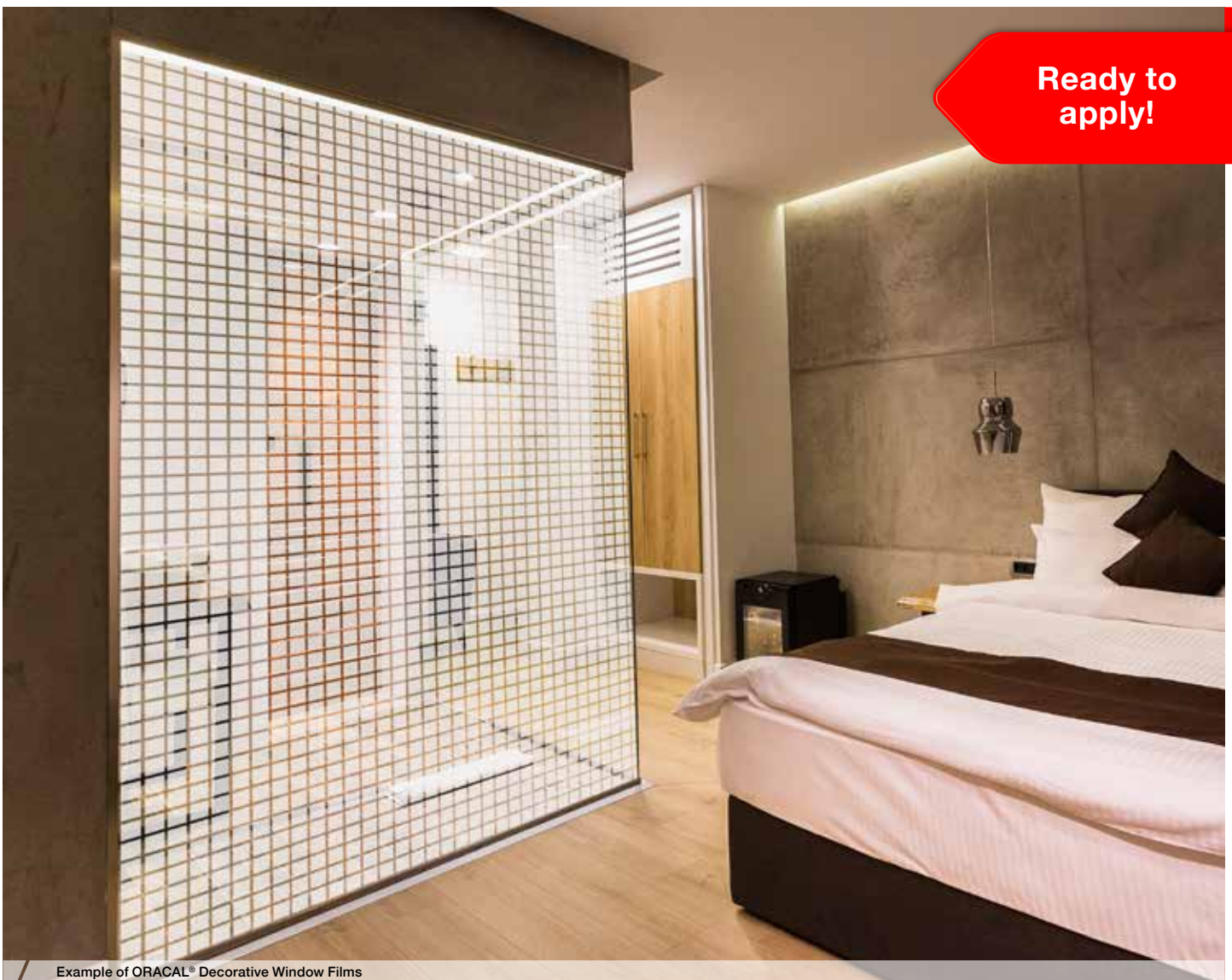
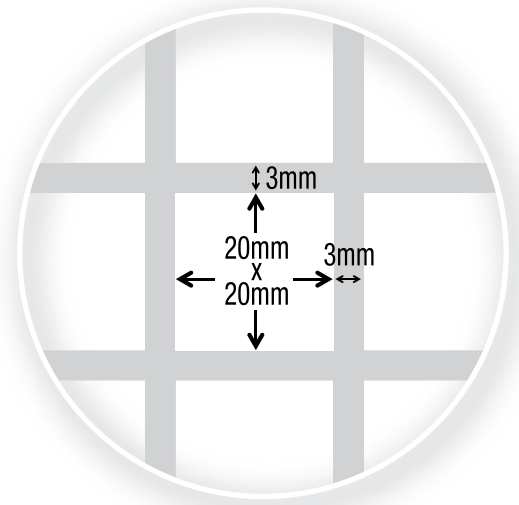

Example of ORACAL® Decorative Window Films

Frosted stripes of 35mm, Interior Design Window Film

ORACAL® UV05

**Product Features:**

- Frosted stripes of 35mm
- 38 micron
- Acrylic copolymer adhesive
- Roll size: 1525mm x 30m
- Wet application is recommended.

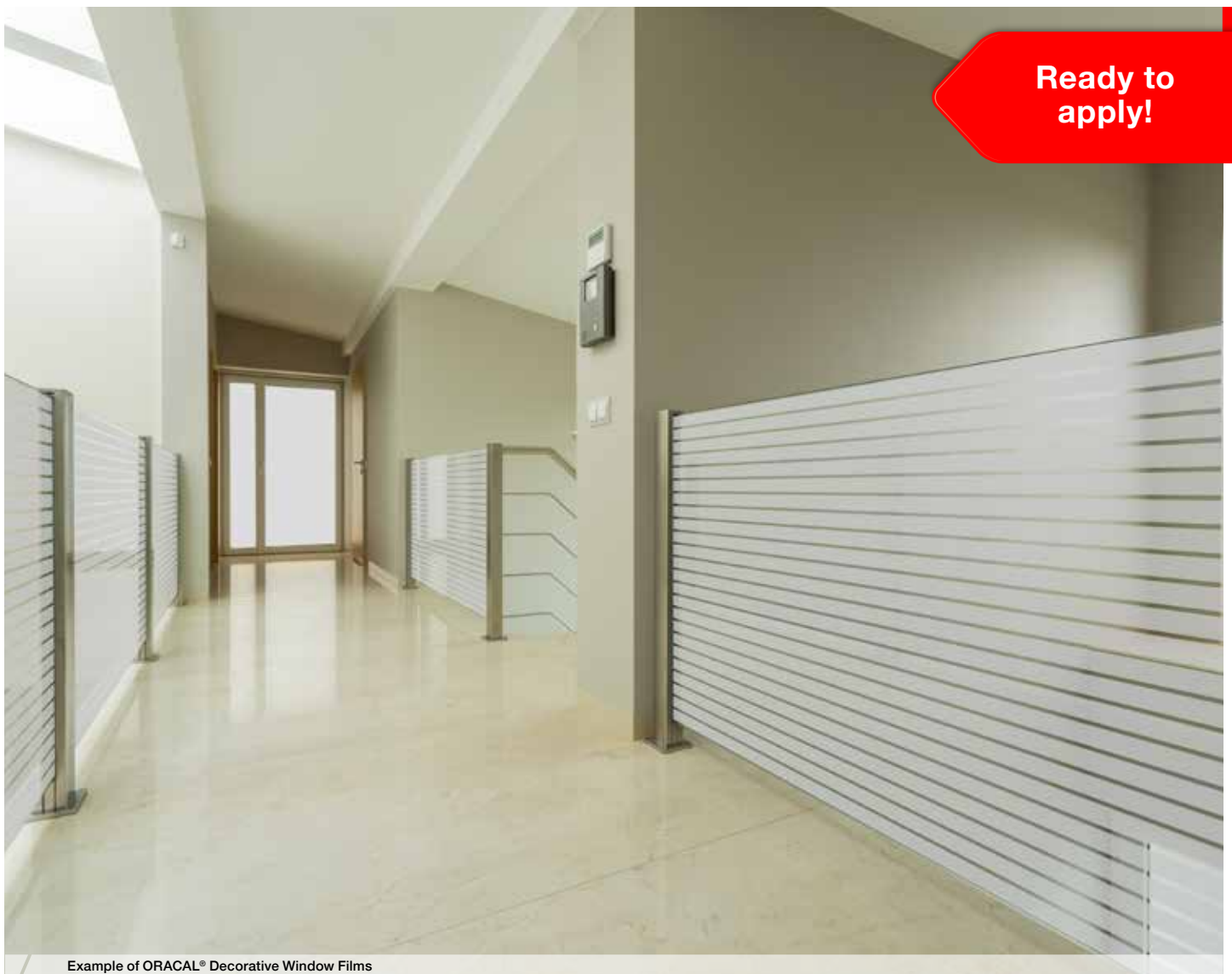
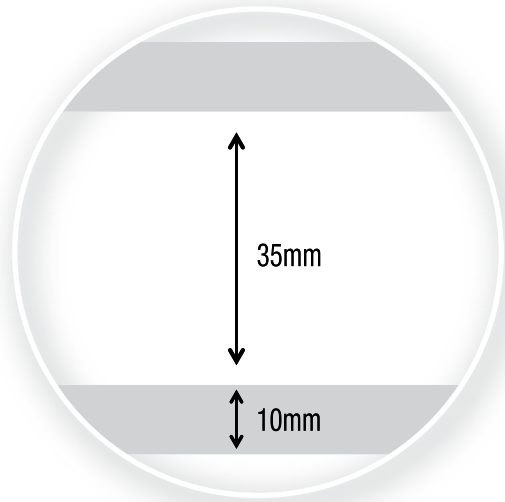

Example of ORACAL® Decorative Window Films



White squares of 10mm, Interior Design Window Film

ORACAL® W002

**Product Features:**

- White squares of 10mm
- 38 micron
- Acrylic copolymer adhesive
- Roll size: 1525mm x 30m
- Wet application is recommended.

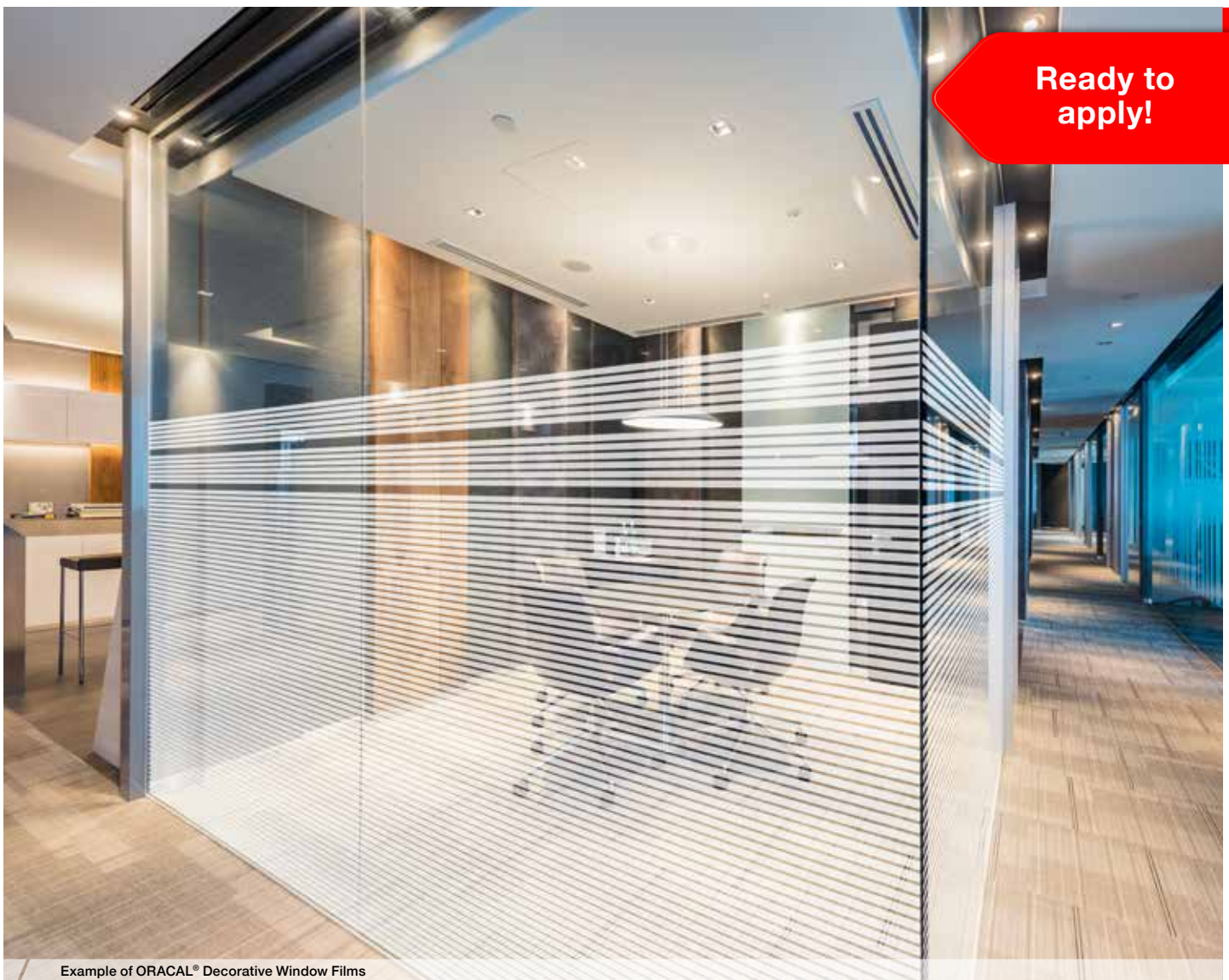
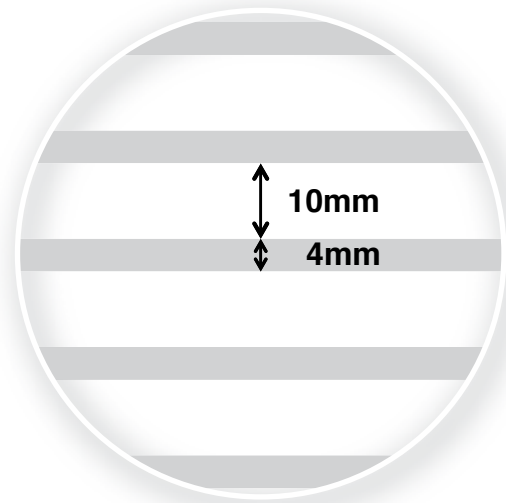

Example of ORACAL® Decorative Window Films



White Cocoon, Interior Design Window Film

ORACAL® W018

**Product Features:**

- White Cocoon design pattern
- 38 micron
- Acrylic copolymer adhesive
- Roll size: 1525mm x 30m
- Wet application is recommended.

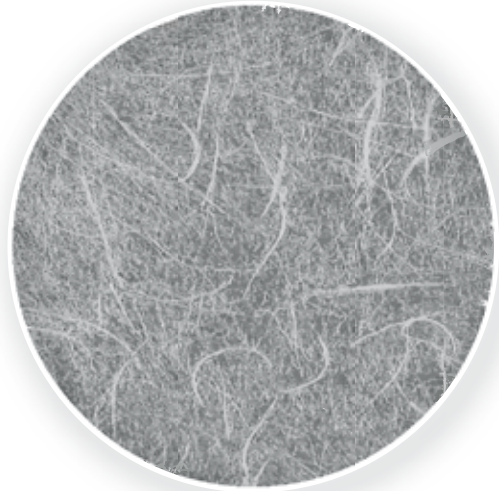

Example of ORACAL® Decorative Window Films

White stripes of 30mm, Interior Design Window Film

ORACAL® W004

**Product Features:**

- White stripes of 30mm
- 38 micron
- Acrylic copolymer adhesive
- Roll size: 1525mm x 30m
- Wet application is recommended.

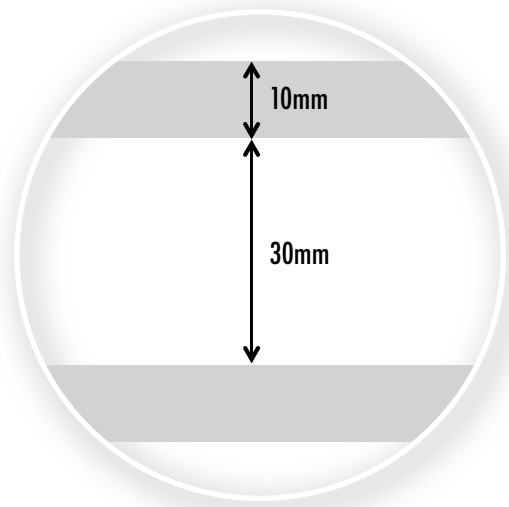

Frosted stripes of 5mm and 35mm, Interior Design Window Film

ORACAL® UV10

**Product Features:**

- Frosted stripes of 5mm and 35mm
- 38 micron
- Acrylic copolymer adhesive
- Roll size: 1525mm x 30m
- Wet application is recommended.

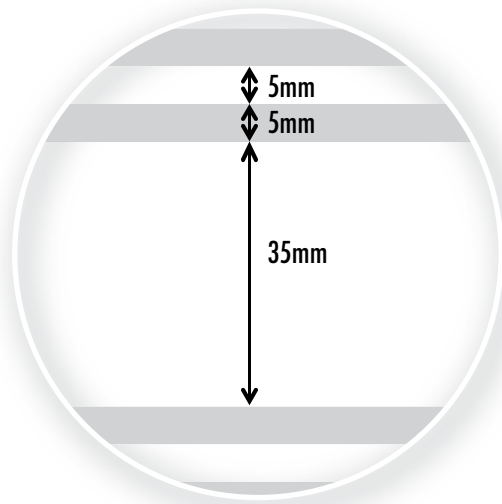

Example of ORACAL® Decorative Window Films



Frosted Squares of 44mm, Interior Design Window Film

ORACAL® UV11

**Product Features:**

- Frosted Squares of 44mm
- 38 micron
- Acrylic copolymer adhesive
- Roll size: 1525mm x 30m
- Wet application is recommended.

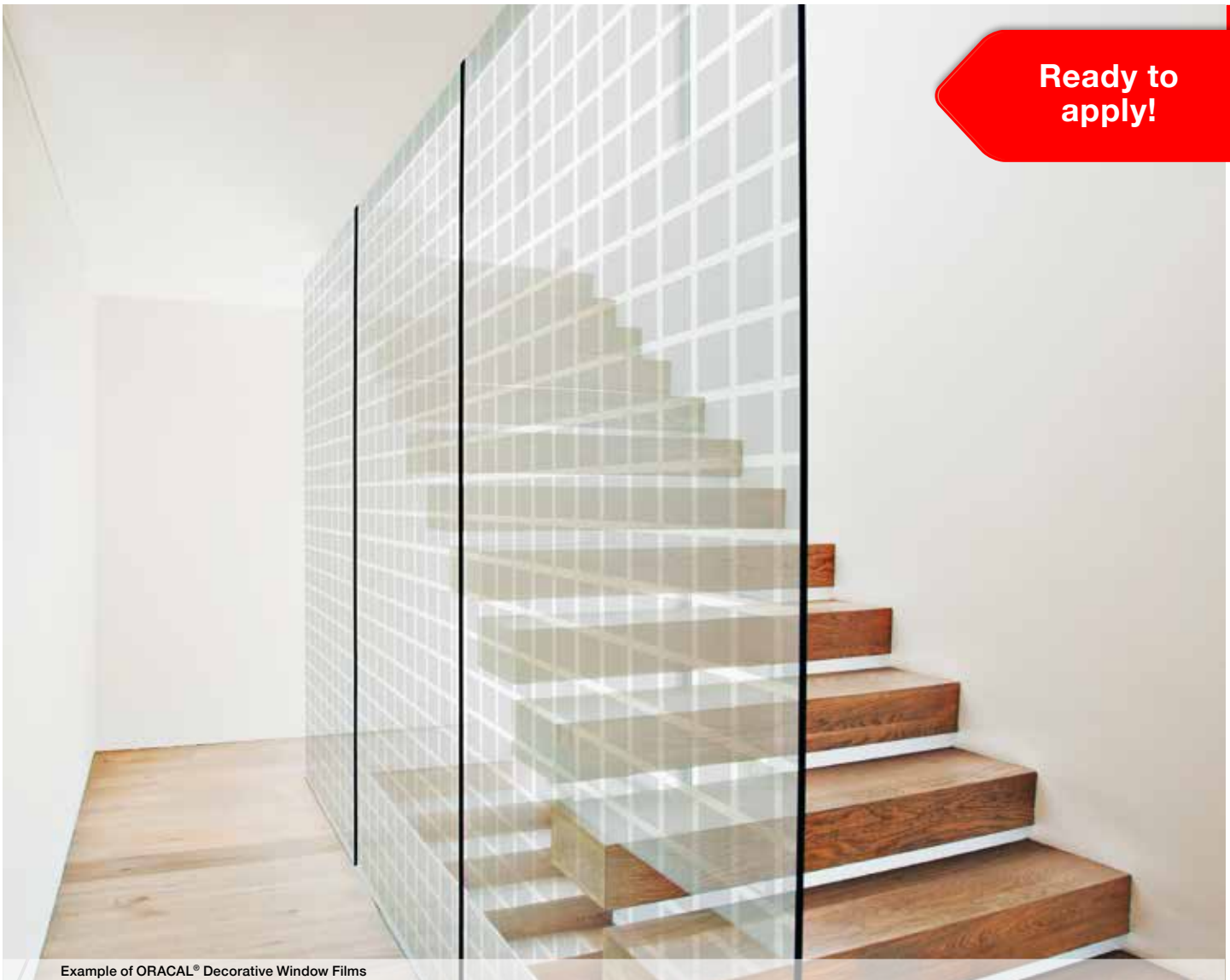
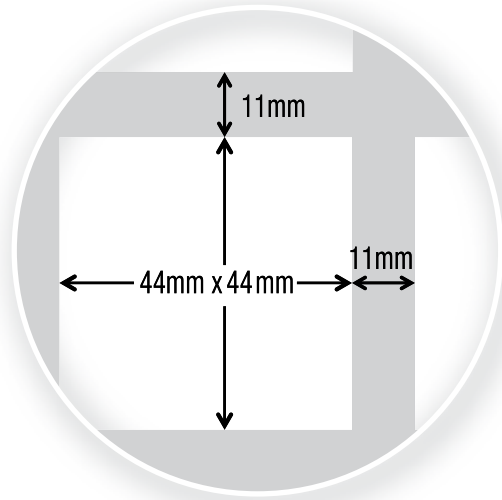

**Ready to apply!**

Example of ORACAL® Decorative Window Films

**White Matt Interior Design Window Film**

**ORACAL® WM20**

**Product Features:**

- White Matt film
- 38 micron
- Acrylic copolymer adhesive
- Roll size: 1525mm x 30m
- Wet application is recommended.



Example of ORACAL® Decorative Window Films

### Transparent Cal

# ORACAL<sup>®</sup> 8300

Transparent film in 32 attractive colours for indoor and outdoor decorative design use on glass and plexiglass, especially window graphics.

#### Product benefits include:

- Transparent PVC film (80 micron) with UV stabilisers
- 32 glossy colours
- Solvent polyacrylate, permanent, transparent
- Dry and wet application



Example of ORACAL<sup>®</sup> 8300 Transparent Cal / Photo: Courtesy of Ryerson, USA



### Optical Clear Film

# ORAJET® 3352F

With the new digital printing film ORAJET® 3352F Optical Clear Film from ORAFOL, installation of glass decorations has never been easier. This optically clear film can be digitally printed, and the printed designs are then installed in full sheets making installation faster and easier than ever. In the areas on the film where there is no print, the ORAJET® 3352F film is so clear that it is hard to even notice the film. The film is suitable for indoor and short-term outdoor application and is easily removable.

#### Product benefits include:

- Ultra transparent top-coated polyester film (70 micron)
- Available with a glossy surface
- For indoor and short-term outdoor application on windows
- Wet installation possible
- Inkjet printing with solvent based inks, UV- or Latex inks
- Solvent polyacrylate, removable



Example of ORAJET® 3352F

## Etched Glass Cal

# ORACAL® 8510

Used for decorative design of shop windows and glass doors. Available in gold and silver-grey with hoarfrost effect, or an impression of etched, cut or sandblasted glass.

### Product benefits include:

- Polymer PVC film (80 micron)
- Coarse and fine structure
- Wet application is recommended
- Solvent polyacrylate, permanent, transparent

## Etched Glass Cal – with *RapidAir*® Technology

# ORACAL® 8510RA



### RA product benefits also include:

- The *RapidAir*® technology allows a rapid and bubble-free application
- *RapidAir*® requires less application time and cost

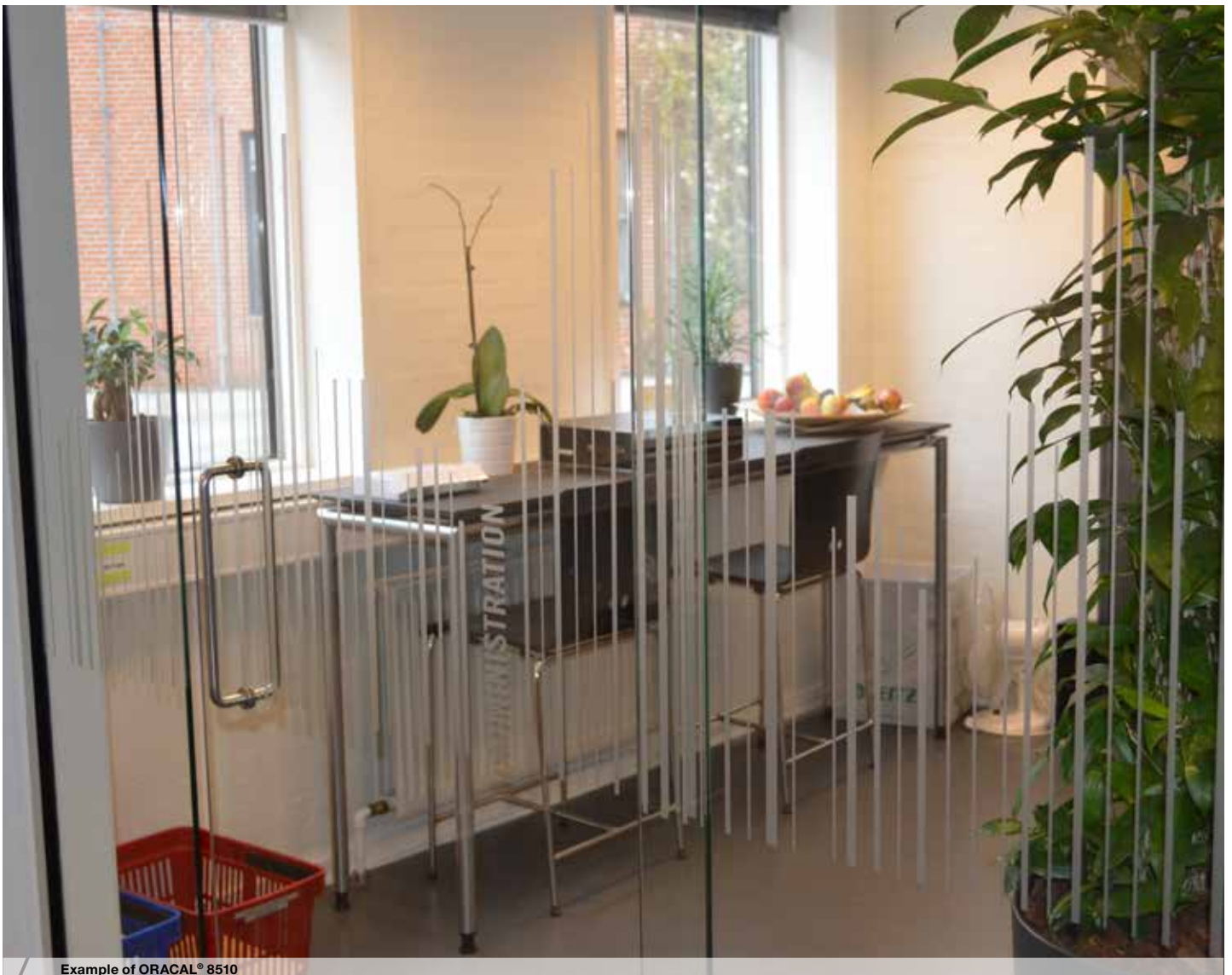

Example of ORACAL® 8510



### Etched Glass Cal

# ORACAL® 8530

Exceptionally easy to remove

**Product benefits include:**

- Polymer PVC film (80 micron)
- **Exceptionally easy to remove**
- In silver with hoarfrost effect, or an impression of etched, cut or sandblasted glass (coarse and fine structure)
- For the decorative design of shop windows and glass doors
- Solvent polyacrylate, removable



Example of ORACAL® 8530



### Dusted Glass Cal

# ORACAL® 8710

Even more possibilities for decorative designs of glass areas, such as shop windows, room dividers and glass doors. Creates the look of a rough glass surface.



#### Product benefits include:

- Polymer PVC film (70 micron)
- Medium glossy surface prevents unwanted light reflections
- Wet application is recommended
- Solvent polyacrylate, permanent, transparent



Example of ORACAL® 8710

### Frosted Glass Cast

# ORACAL® 8810

For extra high quality glass decoration of shop windows and glass doors. Five variants available with hoarfrost effect.



#### Product benefits include:

- Cast high-performance PVC film (80 micron)
- Eye-catching, glamorous glitter effects
- Extreme resistance to weathering and UV
- Wet application is recommended
- Solvent polyacrylate, permanent, transparent



Example of ORACAL® 8810

Decorative Window Films  
**Engineered to Perform Better™**



**ORAFOL Turkey A.Ş.**  
**Akçaburgaz Mh. 9. Cd. 117. Sk. No:5 Kıraç / Esenyurt**  
**34522 İstanbul, Türkiye**  
Telefon: +90 212 671 26 83  
Faks : +90 212 671 26 85  
Web Sitesi: [www.orafol.com.tr](http://www.orafol.com.tr)

